

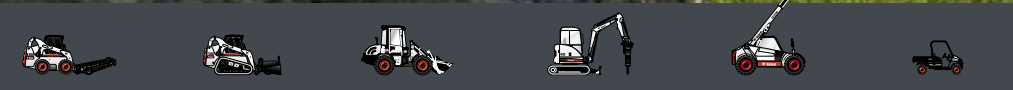

Bobcat®

S250

Compact Loaders



Machine Rating

Rated operating capacity	1284 kg
Tipping load	2568 kg
Pump capacity – S250	78.4 l/min
Pump capacity – S250H	151 l/min
System relief at quick couplers	22.4–23.1 MPa
Max. travel speed (low range)	10.6 km/h
Max. travel speed (high range - option)	18.5 km/h

Engine

Make / Model	Kubota / V3800-DI-T-E3
Fuel / Cooling	Diesel / Liquid
Power	54 kW
Torque, maximum at 1500 RPM (SAE J1 995 Gross)	278 Nm
Number of cylinders	4
Displacement	3769 cm ³
Fuel tank capacity	87.1 l

Weights

Operating weight, S250	3549 kg
Operating weight, S250H	3570 kg

Controls

Vehicle steering	Direction and speed controlled by two hand levers
Loader hydraulics tilt and lift	Separate foot pedals or optional Advanced Control System (ACS) or Selectable Joystick Control (SJC)
Front auxiliary (standard)	Electrical switch on right-hand steering lever

Drive System

Transmission	Infinitely variable tandem hydrostatic piston pumps, driving two fully reversing hydrostatic motors
--------------	---

Standard Features

High-back cushion suspension seat	Engine/hydraulics system shutdown
Automatically activated air intake heater	Hydraulic bucket positioning
Bob-Tach™ frame	Instrumentation
Bobcat Interlock Control System (BICS)	Lift arm support
Counterweights: four axle weight sets and two tailgate plate weights	Operating lights, front and rear
Deluxe operator cab	Parking brake
Includes interior cab foam, side, top and rear windows	Seat belt
Electrically activated proportional front auxiliary hydraulics	Seat bar
	12 x 16.5, 12-ply, Heavy duty tyres
	CE certification
	Turbo-charger with approved spark arrestor
	Warranty: 12 months or 2000 hours

* Roll Over Protective Structure (ROPS) – meets requirements of SAE-J1040 and ISO 3471; Falling Object Protective Structure (FOPS) - meets requirements of SAE-J1043 and ISO 3449, Level I

Options

Two speed	12 x 16.5, 12-ply, Severe duty tyres
High-flow hydraulics	12 x 16.5, 12-ply, Severe duty tyres, poly filled
Deluxe instrument panel	Steel track package to fit 12-16.5 tyres
Cab enclosure with heat	Air conditioning
Power Bob-Tach™	Advanced Control System (ACS)
33 x 15.5-16.5, 12-ply, Superflotation tyres, offset rims	Advanced Hand Controls (AHC)
12 x 16.5, 12-ply, Heavy duty tyres, offset rims	Selectable Joystick Controls (SJC)

Dimensions

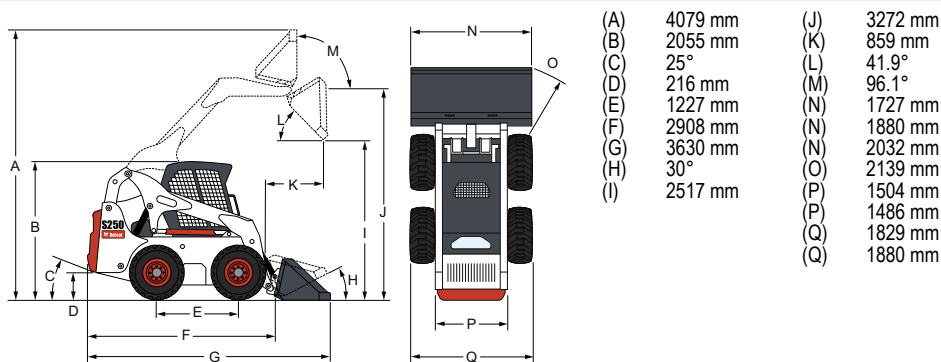

Attachments

- Angle blade
- Angle broom*†
- Auger
- Backhoe
- Box blade
- Brushcat rotary cutter
- Buckets
- Chipper*
- Combination bucket
- Concrete pump*
- Cutter crusher*
- Digger
- Dozer blade*
- Dumping hopper
- Farm grapple
- Grader*
- Hydraulic breaker**
- Industrial grapple
- Landplane
- Landscape rake
- Mixing bucket*
- Pallet fork – standard
- Pallet fork – hydraulic
- Planer*
- Rear stabiliser
- Scarifier
- Snow blower*
- Sod layer*
- Soil conditioner*
- Spreader
- Stump grinder*
- Super scraper
- Sweeper
- Three-point hitch
- Tiller
- Tilt-Tatch™
- Tracks, steel
- Tree transplanter*
- Trench compactor
- Trencher
- Utility forks
- Utility frame
- Vibratory roller
- Water kit
- Wheel saw
- Whisker broom

*Attachment control kit required.

**When operating the loader with this attachment, a Special Applications Kit, which includes a 12 mm Lexan front door with 6 mm top and rear windows, must be used.

†Optional water kit.



www.bobcat.eu